

SD250HV

DC/DC Converter



SYSTEM FEATURES



HIGH YIELD

- Max. efficiency 99.0%
- Effective forced air cooling, 1.1 overload capacity
- Wide DC voltage operation window, flexible for battery configuration



EASY O&M

- Compact design and modular design for easy installation
- Scalable system configuration, extend to MW power range



ESS APPLICATIONS

- Battery charge & dis-charge management integrated Bidirectional power conversion system
- Compatible with high voltage battery system, low system cost



PV+ESS

- Higher system efficiency, Bi-directional buck-boost design for better voltage matching
- Designed for PV DC-Coupled ESS solution

CIRCUIT DIAGRAM

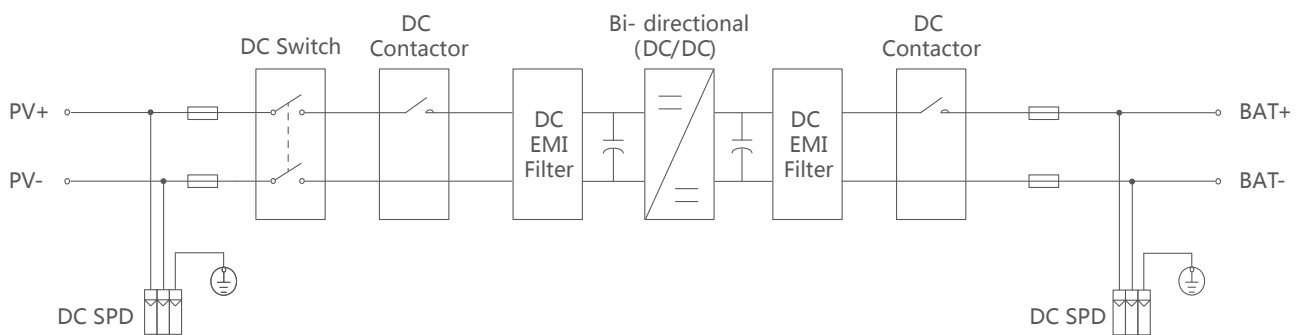

System Type	SD250HV
Power Rating	
Nominal power	250 kW
Max. power	275 kW
PV Side Data	
Max. working voltage range	500 ~ 1,500 V
MPPT voltage range at nominal power	800 ~ 1,300 V
Max. current	343 A
Battery Side Data	
Max. working voltage range	500 ~ 1,500 V
Voltage range at nominal power	800 ~ 1,300 V
Max. current	343 A
Efficiency	
Max. efficiency	99.0 %
General Data	
Dimensions (W * H * D)	806 * 2,034 * 706 mm / 31.7" * 80.1" * 27.8"
Weight	300 kg / 661 lbs.
Degree of protection	IP 21 / NEMA 2
Operating temperature range	-30 ~ 55 °C / -22 ~ 131 °F
Relative humidity	0 ~ 95 % (No-condensing)
Max. working altitude	3,000 m (> 2,000 m derating) / 9,843' (> 6,562' derating)
Display	Touch screen
Cooling concept	Temperature-controlled forced air cooling
Aux. power requirement	400 / 480 / 540 VAC, 50Hz, 1kVA
Multiple parallel operation	Support
Communication port	RS485, Ethernet, CAN
Communication protocol	Modbus RTU, Modbus TCP, IEC104
Compliance	TÜV

